

Qierling (Beijing) Health Technology Co., Ltd.

TEST REPORT

SCOPE OF WORK

EMC TESTING—SEE PAGE 2

REPORT NUMBER

201225119GZU-003

ISSUE DATE

26-February-2021

[REVISED DATE]

[-----]

PAGES

30

DOCUMENT CONTROL NUMBER

ETSI EN 301 489-17-e

© 2017 INTERTEK



TEST REPORT

Applicant Name & Address : Qierling (Beijing) Health Technology Co., Ltd.
No 101-42/101-43 (Dongsheng district) , 9th Floor, No 1 Building,
No 8th , Heiquan Road, Haidian District, Beijing City, China.

Manufacturing Site : Healthlead Corproation Limited
Building A, Digital Silicone Valley Industry Park, No. 89, Hengping
Road, Henggang Street, Longgang District, Shenzhen, P.R. China

Intertek Report No: : 201225119GZU-003

Test standards

ETSI EN 301 489-1 V2.2.3 (2019-11)
ETSI EN 301 489-17 V3.2.4 (2020-09)

Sample Description

Product : Air Purifiering Disinfector
Model No. : DS-X400W, DS-P400, DS-S800, DS-X1000W
Electrical Rating : 100V-240V, 50Hz, 38W for model DS-X400W, DS-P400
220V-240V, 50Hz, 90W for model DS-S800
220V-240V, 50Hz, 120W for model DS-X1000W

Serial No. : Not Labeled
Date Received : 25 December 2020
Date Test : 15 January 2021 to 22 January 2021
Conducted

Prepared and Checked By



Elena Lei
Engineer

Approved By:



Helen Ma
Team Leader

This report is for the exclusive use of Intertek's Client and is provided pursuant to the agreement between Intertek and its Client. Intertek's responsibility and liability are limited to the terms and conditions of the agreement. Intertek assumes no liability to any party, other than to the Client in accordance with the agreement, for any loss, expense or damage occasioned by the use of this report. Only the Client is authorized to permit copying or distribution of this report and then only in its entirety. Any use of the Intertek name or one of its marks for the sale or advertisement of the tested material, product or service must first be approved in writing by Intertek. The observations and test results in this report are relevant only to the sample tested. This report by itself does not imply that the material, product, or service is or has ever been under an Intertek certification program.

Intertek Testing Services Shenzhen Ltd. Guangzhou Branch
Room 02, & 101/E201/E301/E401/E501/E601/E701/E801 of Room 01 1-8/F., No. 7-2. Caipin Road, Science City, GETDD,
Guangzhou, Guangdong, China

TEST REPORT

CONTENT

TESTREPORT	1
CONTENT	3
1. TEST RESULTS SUMMARY	4
2. EMC RESULTS CONCLUSION	5
3. LABORATORY MEASUREMENTS	6
4. EQUIPMENT USED DURING TEST	7
5. EMI TEST	9
5.1 CONTINUOUS CONDUCTED DISTURBANCE VOLTAGE TEST	9
5.1.1 <i>Block Diagram of Test Setup</i>	9
5.1.2 <i>Test Setup and Procedure</i>	9
5.1.3 <i>Test Data and curve</i>	10
5.2 RADIATED DISTURBANCE	12
6. HARMONICS OF CURRENT	12
6.1 BLOCK DIAGRAM OF TEST SETUP	12
6.2 TEST SETUP AND PROCEDURE.....	12
7. FLICKER	13
7.1 BLOCK DIAGRAM OF TEST SETUP	13
7.2 TEST SETUP AND PROCEDURE.....	13
8. EMS TEST	14
8.1 ELECTROSTATIC DISCHARGE IMMUNITY.....	15
8.2 RADIATED ELECTROMAGNETIC FIELD IMMUNITY.....	19
8.3 ELECTRICAL FAST TRANSIENT/BURST	22
8.4 SURGE IMMUNITY	23
8.5 INJECTED CURRENT.....	24
8.6 VOLTAGE DIPS AND INTERRUPTIONS.....	26
9. APPENDIX I - PHOTOS OF TEST SETUP	28
10. APPENDIX II – PHOTOS OF EUT	30

TEST REPORT

1. TEST RESULTS SUMMARY

Test Item	Standard		Result
	ETSI EN 301 489-17	ETSI EN 301 489-1	
Continuous conducted disturbance voltage	7.1	8.4	Pass
Radiated disturbance	7.1	8.2	N/A
Harmonic of current	7.1	8.5	Pass
Flicker	7.1	8.6	Pass
ESD immunity	7.2	9.3	Pass
Radiated EM field immunity	7.2	9.2	Pass
EFT immunity	7.2	9.4	Pass
Surge immunity	7.2	9.8	Pass
Inject current immunity	7.2	9.5	Pass
Voltage dips and interruption immunity	7.2	9.7	Pass

Remark:

1. The symbol "N/A" in above table means Not Applicable.
2. When determining the test results, measurement uncertainty of tests has been considered.

TEST REPORT

2. EMC RESULTS CONCLUSION

RE: EMC Testing Pursuant to Radio Equipment Directive 2014/53/EU Performed on the Air Purifying Disinfector, Models: DS-X400W, DS-P400, DS-S800, DS-X1000W.

Models difference:

Model	NFC	WIFI module	Motor /ratings	Ratings
DS-X400W	----	With	DNQ12M84R25F/ DC24 V	100V-240V, 50Hz, 38W
DS-P400	----	With	DNQ12M84R25F/ DC24 V	100V-240V, 50Hz, 38W
DS-S800	With	With	ZWF-75L/ DC310V; 75W; 0,34A	220V-240V, 50Hz, 90W
DS-X1000W	With	With	SIC-58CS-F185-1/ DC310V; 85W, 0,34A;	220V-240V, 50Hz, 120W
Remark: DS-X400W and DS-P400 have different model names.The two models are identical.				

We tested the Air Purifying Disinfector, Models: DS-X400W, to determine if it was in compliance with the relevant EN standards as marked on the Test Results Summary. We found that the unit met the requirements of ETSI EN 301 489-1, ETSI EN 301 489-17 standards when tested as received. The worst case's test data was presented in this test report.

Remark: The DS-S800, DS-X1000W are involved in NFC testing in the report 201225119GZU-003.

The production units are required to conform to the initial sample as received when the units are placed on the market.

TEST REPORT

3. LABORATORY MEASUREMENTS

Configuration Information

Support Equipment:	N/A
Rated Voltage and frequency under test:	DS-X400W & DS-P400&:100-240V/50Hz DS-S800, DS-X1000W:200V-240V/50Hz
Condition of Environment:	Temperature: 22~28°C Relative Humidity:35~60% Atmosphere Pressure:86~106kPa

Notes:

1. The EMI measurements had been made in the operating mode produced the largest emission in the frequency band being investigated consistent with normal applications. An attempt had been made to maximize the emission by varying the configuration of the EUT.

2. The EMS measurements had been made in the frequency bands being investigated, with the EUT in the most susceptible operating mode consistent with normal applications. The configuration of the test sample had been varied to achieve maximum susceptibility.

3. Test Location:

Intertek Testing Services Shenzhen Ltd. Guangzhou Branch

All tests were performed at:

Room 02, & 101/E201/E301/E401/E501/E601/E701/E801 of Room 01 1-8/F., No. 7-2. Caipin Road, Science City, GETDD, Guangzhou, Guangdong, China

Except Radiated Disturbance and Radiated Susceptibility were performed at:
Room102/104, No 203, KeZhu Road, Science City, GETDD Guangzhou, China

4. Measurement Uncertainty

No.	Item	Measurement Uncertainty
1	Conducted Emission (9 kHz-150 kHz)	2.79 dB
2	Conducted Emission (150 kHz-30 MHz)	2.55 dB
3	Disturbance Power (30 MHz-300 MHz)	3.04 dB
4	Radiated Emission (30 MHz-1 GHz)	4.80 dB
5	Radiated Emission (1 GHz-6 GHz)	4.97 dB
6	Radiated Emission (6 GHz-18 GHz)	4.89 dB

The measurement uncertainty describes the overall uncertainty of the given measured value during the operation of the EUT.

Measurement uncertainty is calculated in accordance with CISPR16-4-2:2011+A1:2014+A2:2018.

The measurement uncertainty is given with a confidence of 95%, k=2.

Determination of the test conclusion is based on IEC Guide 115 in consideration of measurement uncertainty.

TEST REPORT

4. EQUIPMENT USED DURING TEST

Conducted Disturbance-Mains Terminal(2)

Equipment No.	Equipment	Model	Manufacturer	Cal. Due date (DD-MM-YYYY)	Calibration Interval
EM031-04	EMI receiver	ESR3	R&S	07/01/2022	1Y
EM006-06	LISN	ENV216	R&S	06/09/2021	1Y
SA047-111	Digital Temperature-Humidity Recorder	RS210	YIJIE	16/11/2021	1Y
EM004-03	EMC shield Room	8m×4m×3m	Zhongyu	21/01/2023	2Y
EM031-04-01	EMC32 software (CE)	V10.01.00	R&S	N/A	N/A

Electrostatic Discharge(1)

Equipment No.	Equipment	Model	Manufacturer	Cal. Due date (DD-MM-YYYY)	Calibration Interval
EM077-04	ESD Simulator	NSG437	TESEQ	15/04/2021	1Y
SA047-133	Digital Temperature-Humidity Recorder	AW5145Y	ASAIR	16/03/2021	1Y

Electrical Fast Transient/Burst(2)

Equipment No.	Equipment	Model	Manufacturer	Cal. Due date (DD-MM-YYYY)	Calibration Interval
EM005-10	EFT Generator	NSG3025	TESEQ	05/05/2021	1Y
EM005-10-01	Capacitive Coupling Clamp	CDN8014	TESEQ	15/04/2021	1Y
SA047-140	Digital Temperature-Humidity Recorder	AW5145Y	ASAIR	05/01/2022	1Y

Surge(3)

Equipment No.	Equipment	Model	Manufacturer	Cal. Due date (DD-MM-YYYY)	Calibration Interval
EM005-09	Surge/DIP Generator	NSG3040	TESEQ	22/06/2021	1Y
SA047-140	Digital Temperature-Humidity Recorder	AW5145Y	ASAIR	05/01/2022	1Y

TEST REPORT

Conducted Susceptibility(2)

Equipment No.	Equipment	Model	Manufacturer	Cal. Due date (DD-MM-YYYY)	Calibration Interval
EM019-01	Conducted Immunity Testing System	NSG4070-75	Teseq GmbH	19/04/2021	1Y
EM019-01-01	Current Electromagnetic injection clamp	KEMZ801S	Teseq GmbH	06/09/2021	1Y
EM019-01-02	Coupling&Decoupling Network	CDNM016	Teseq GmbH	06/09/2021	1Y
EM019-01-03	6dB Attenuator	ATN6075	Teseq GmbH	06/09/2021	1Y
EM019-03	Current Clamp	CIP 9136A	Teseq GmbH	19/07/2021	1Y
SA047-140	Digital Temperature-Humidity Recorder	AW5145Y	ASAIR	05/01/2022	1Y

Voltage Dips and Interruptions(2)

Equipment No.	Equipment	Model	Manufacturer	Cal. Due date (DD-MM-YYYY)	Calibration Interval
EM005-09	Surge/DIP Generator	NSG3040	TESEQ	22/06/2021	1Y
EM005-09-01	Voltage Regulator	INA6501	TESEQ	22/06/2021	1Y
SA047-140	Digital Temperature-Humidity Recorder	AW5145Y	ASAIR	05/01/2022	1Y

Radiated Susceptibility

Equipment No.	Equipment	Model	Manufacturer	Cal. Due date (DD-MM-YYYY)	Calibration Interval
EM030-04	3m Semi-Anechoic Chamber	9x6x6 m ³	ETS LINDGREN	10/04/2021	1Y
EM031-01	Signal generator	SMB100A	R&S	22/07/2021	1Y
EM086-11	Power meter	NRP2	R&S	15/11/2021	1Y
EM086-11-01	Power sensor	NRP-Z91	R&S	15/11/2021	1Y
EM046-01	Power Amplifier	80RF1000-300	MILMEGA	19/03/2021	1Y
EM046-03	Power Amplifier	AS0860-75-45	MILMEGA	06/09/2021	1Y
EM061-05	Log. - Per. Broadband Antenna	VULP 9118 E	SCHWARZBECK	11/10/2021	2Y
EM061-07	Stacked Log.-Per. Broadband Antenna	STLP 9149	SCHWARZBECK	11/10/2021	2Y
EM034-01	Open Switch and Control Platform	OSP120/1505.3009K12	R&S	/	1Y
EM045-01-01	EMC32 software (RE/RS)	V10.01.00	R&S	/	1Y
SA047-118	Digital Temperature-Humidity Recorder	RS210	YIJIE	21/07/2021	1Y

TEST REPORT

5. EMI TEST

5.1 Continuous Conducted Disturbance Voltage Test

Basic Standard :	EN 55032: 2015
Classification :	Class B
Port :	AC mains input ports

5.1.1 Block Diagram of Test Setup

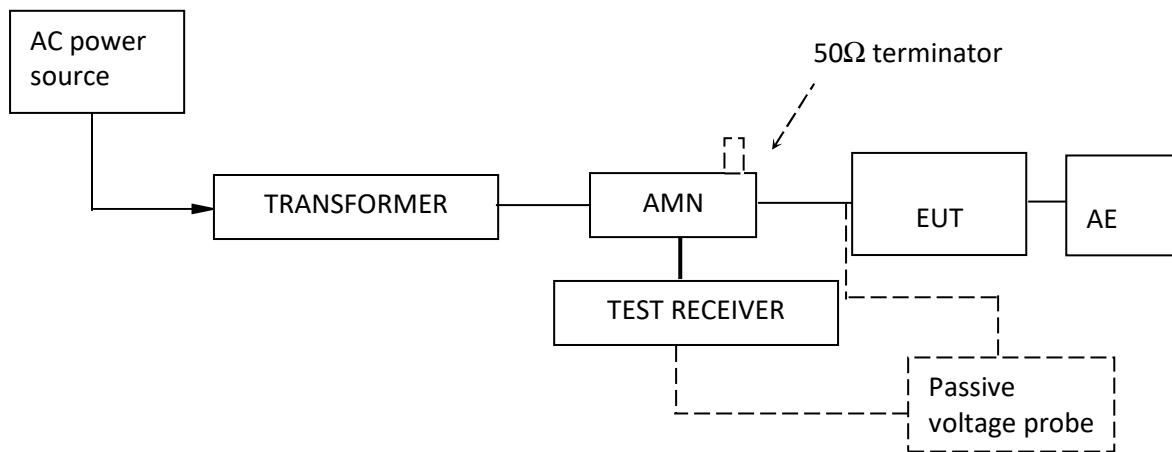

5.1.2 Test Setup and Procedure

The EUT was set to achieve the maximum emission level. The mains terminal disturbance voltage was measured with the EUT in a shielded room. The EUT was connected to AC power source through an Artificial Mains Network which provides a 50Ω linear impedance Artificial hand is used if appropriate (for handheld apparatus). The load/control terminal disturbance voltage was measured with passive voltage probe if appropriate.

The table-top EUT was placed on a 0.4m high non-metallic table above earthed ground plane(Ground Reference Plane).And for floor standing EUT, was placed on a 0.1m high non-metallic supported on GRP. The EUT keeps a distance of at least 0.8m from any other of the metallic surface. The Artificial Mains Network is situated at a distance of 0.8m from the EUT.

During the test, mains lead of EUT excess 0.8m was folded back and forth parallel to the lead so as to form a horizontal bundle with a length between 0.3m and 0.4m.

The bandwidth of test receiver was set at 9 kHz. The frequency range from 150 kHz to 30MHz was checked.

When measurements of disturbance are being made, the appliance shall be operated under the conditions defined in clause 7.

TEST REPORT

5.1.3 Test Data and curve

At mains terminal:

Tested Wire: Live

Operation Mode: wireless connection

Full Spectrum

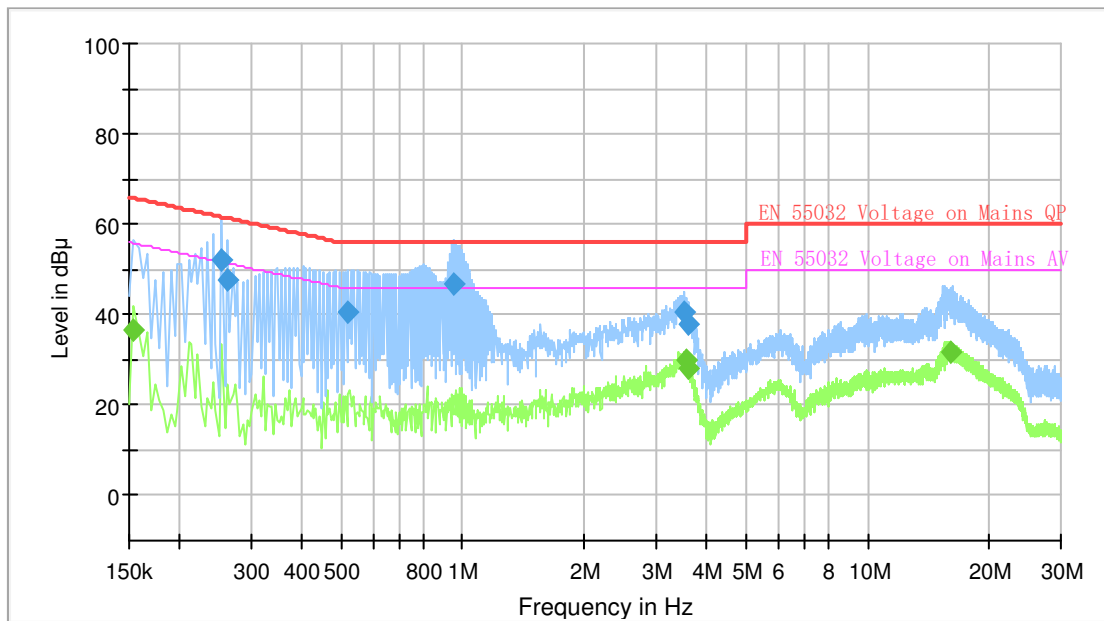

Final_Result

Frequency (MHz)	QuasiPeak (dBµV)	CAverage (dBµV)	Limit (dBµV)	Margin (dB)	Meas. Time (ms)	Bandwidth (kHz)	Line	Filter	Corr. (dB)
0.154000	---	36.62	55.78	19.16	1000.0	9.000	L1	ON	9.6
0.254000	52.23	---	61.63	9.39	1000.0	9.000	L1	ON	9.6
0.262000	47.77	---	61.37	13.60	1000.0	9.000	L1	ON	9.6
0.522000	40.62	---	56.00	15.38	1000.0	9.000	L1	ON	9.6
0.950000	46.89	---	56.00	9.11	1000.0	9.000	L1	ON	9.7
3.530000	40.43	---	56.00	15.57	1000.0	9.000	L1	ON	9.7
3.550000	---	30.14	46.00	15.86	1000.0	9.000	L1	ON	9.7
3.610000	37.86	---	56.00	18.14	1000.0	9.000	L1	ON	9.7
3.618000	---	28.30	46.00	17.70	1000.0	9.000	L1	ON	9.7
15.958000	---	31.91	50.00	18.09	1000.0	9.000	L1	ON	10.3

TEST REPORT

Tested Wire: Neutral

Operation Mode: wireless connection

Full Spectrum

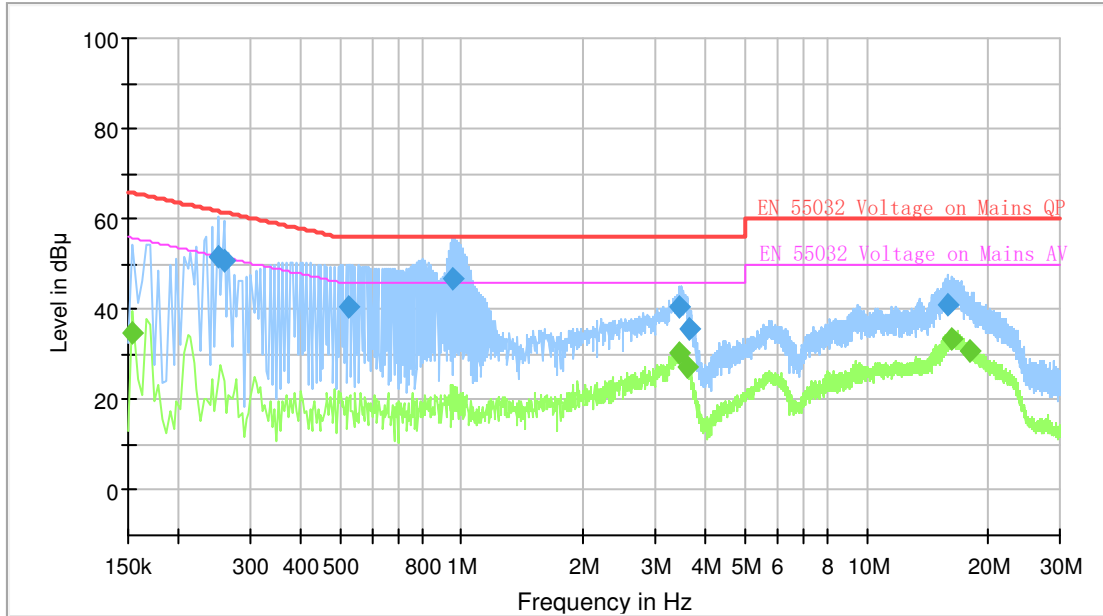

Final Result

Frequency (MHz)	QuasiPeak (dB μ V)	CAverage (dB μ V)	Limit (dB μ V)	Margin (dB)	Meas. Time (ms)	Bandwidth (kHz)	Line	Filter	Corr. (dB)
0.154000	---	34.82	55.78	20.97	1000.0	9.000	N	ON	9.6
0.250000	51.62	---	61.76	10.13	1000.0	9.000	N	ON	9.6
0.258000	50.79	---	61.50	10.71	1000.0	9.000	N	ON	9.6
0.526000	40.65	---	56.00	15.35	1000.0	9.000	N	ON	9.7
0.954000	46.86	---	56.00	9.14	1000.0	9.000	N	ON	9.7
3.438000	---	30.33	46.00	15.67	1000.0	9.000	N	ON	9.7
3.438000	40.62	---	56.00	15.38	1000.0	9.000	N	ON	9.7
3.610000	---	27.08	46.00	18.92	1000.0	9.000	N	ON	9.7
3.646000	35.51	---	56.00	20.49	1000.0	9.000	N	ON	9.7
15.902000	40.83	---	60.00	19.17	1000.0	9.000	N	ON	10.3
16.270000	---	33.54	50.00	16.46	1000.0	9.000	N	ON	10.3
17.906000	---	30.68	50.00	19.32	1000.0	9.000	N	ON	10.3

At load/control terminal:

Not Applicable.

TEST REPORT

5.2 Radiated Disturbance

Test Result: N/A

Remark:

N/A, since there are not any ancillary equipment connected to the radio equipment. The Radiated Emission test is only applicable to ancillary equipment not incorporated in the radio equipment and intended to be measured on a stand-alone basis, as declared by the manufacturer.

6. Harmonics of current

Basic Standard :	EN 61000-3-2: 2014
Classification :	Class A
Port :	AC Mains Input Port

6.1 Block Diagram of Test Setup

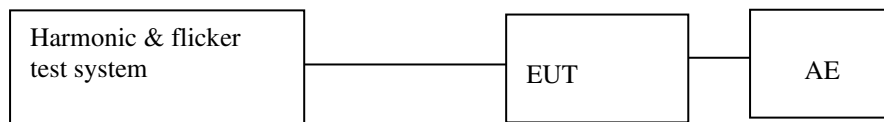

6.2 Test Setup and Procedure

Harmonics of the fundamental current were measured up to 40 order harmonics using a digital power meter with an analogue output and frequency analyser which was integrated in the harmonic & flicker test system. The measurements were carried out under steady conditions.

This product is not defined as lighting equipment, and rated power(WIFI connection) is less than 75W, therefore, no limit applies according to EN 61000-3-2.

TEST REPORT

7. Flicker

Basic Standard :	EN 61000-3-3: 2013
Port :	AC Mains Input Port

7.1 Block Diagram of Test Setup

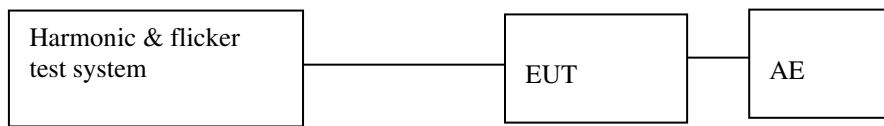

7.2 Test Setup and Procedure

7.2.1 Definition

- Flicker: impression of unsteadiness of visual sensation induced by a lighting stimulus whose luminance or spectral distribution fluctuates with time.
- Pst: Short-term flicker indicator The flicker severity evaluated over a short period (in minutes); Pst=1 is the conventional threshold of irritability
- Plt: long-term flicker indicator; the flicker severity evaluated over a long period (a few hours). Using successive Pst valuse.
- dc: the relative steady-state voltage change
- dmax: the maximum relative voltage change
- d(t): the value during a voltage change

7.2.2 Test condition

The EUT was set to produce the most unfavourable sequence of voltage changes.

This product(WIFI connection) is unlikely to produce significant voltage fluctuations and flicker by examination of the circuit diagram and specification of it. Therefore, it is deemed to fulfill the relevant standard without testing.

TEST REPORT

8. EMS TEST

Performance Criteria of ETSI EN 301 489-17, subclause 6.2 table 1.

Criteria	During Test	After Test
A	Shall operate as intended. (See note). Shall be no loss of function. Shall be no unintentional transmissions.	Shall operate as intended. Shall be no degradation of performance. Shall be no loss of function. Shall be no loss of critical stored data.
B	May be loss of function.	Functions shall be self-recoverable. Shall operate as intended after recovering. Shall be no loss of critical stored data.
C	May be loss of function.	Functions shall be recoverable by the operator. Shall operate as intended after recovering. Shall be no loss of critical stored data.

NOTE: Operate as intended during the test allows a level of degradation in accordance with clause 6.2.2.

performance criteria A for immunity test with phenomena of continuous nature;
performance criteria B for immunity test with phenomena of transient nature;
Performance criteria C for immunity test with power interruptions exceeding a certain time.

Measurement Uncertainty

According to CISPR 16-4-2:2003, measurement uncertainty to immunity test is under consideration.

TEST REPORT

8.1 Electrostatic Discharge Immunity

Basic Standard :	EN 61000-4-2: 2009
Port :	Enclosure
Required Performance Criterion :	Criteria B
Level :	± 2.0, ± 4.0, ±8.0 kV (Air Discharge) ±4.0 kV (Contact Discharge) ±4.0 kV (Indirect Contact Discharge)
Temperature :	23.2°C
Relative Humidity :	58.4 %
No. of Discharge(s) :	Minimum of 10 Discharges per Each Polarity
Time Between Each Discharge :	1 second
Test Mode :	wireless connection & EUT Standby
Test Setup :	Floor-stand
Test of Post-installation :	N/A

TEST REPORT

8.1.1 Block Diagram of Test Setup

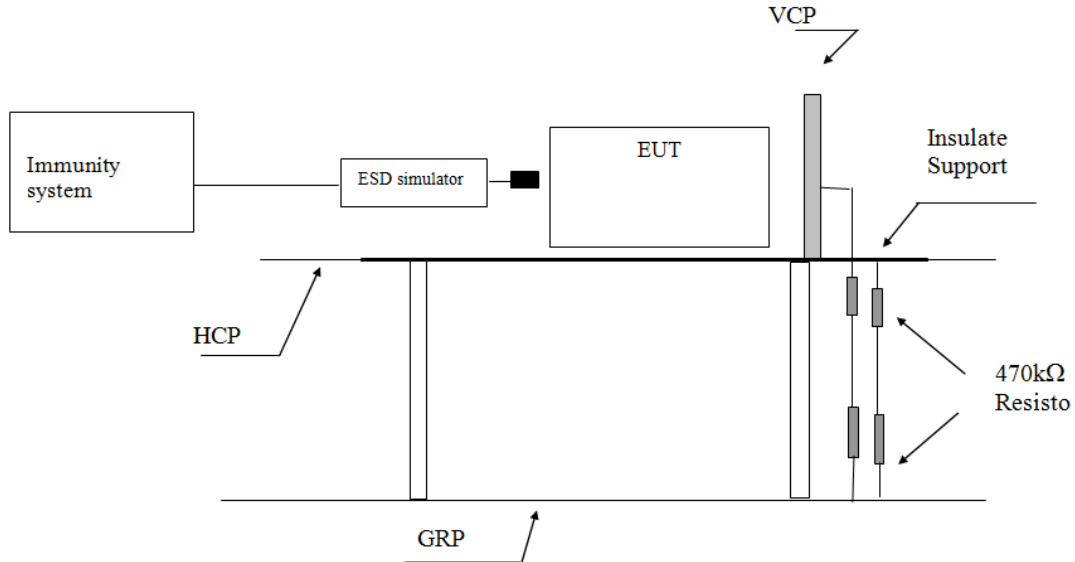

Note: HCP means Horizontal Coupling Plane,

VCP means Vertical Coupling Plane

GRP means Ground Reference Plane

8.1.2 Test Setup and Procedure

The EUT was put on a 0.8m high wooden table 0.1m high for floor standing equipment standing on the ground reference plane (GRP) 3m by 2m in size, made by iron 1.0 mm thick.

A horizontal coupling plane(HCP) 1.6m by 0.8m in size was placed on the table, and the EUT with its cables were isolated from the HCP by an insulating support thick than 0.5mm. The VCP 0.5m by 0.5m in size & HCP were constructed from the same material type & thickness as that of the GRP, and connected to the GRP, and connected to the GRP via a 470kΩ resistor at each end.

The distance between EUT and any of the other metallic surface excepted the GRP, HCP & VCP was greater than 1m.

The EUT was arranged and connected according to its functional requirements.

Direct static electricity discharges were applied only to those points and surface which were accessible to personnel during normal usage.

TEST REPORT

On each preselected points 10 times of each polarity single discharge were applied. The time interval between successive single discharges was at least 1s.

The ESD generator was held perpendicular to the surface to which the discharge was applied. The discharge return cable of the generator was kept at a distance of 0.2m whilst the discharge was being applied. During the contact discharges, the tip of the discharge electrode was touched the EUT before the discharge switch was operated. During the air discharges, the round discharge tip of the discharge electrode was approached as fast as possible to touch the EUT.

Indirect discharge was conducted to objects placed near the EUT, simulated by applying the discharges of the ESD generator to a coupling plane, in the contact discharge mode.

After each discharge, the ESD generator was removed from the EUT, the generator was then retriggered for a new single discharge. For ungrounded product, a grounded carbon fibre brush with bleeder resistors (2x470 kΩ) in the grounding cable was used after each discharge to remove remnant electrostatic voltage.

For air discharge, a minimum of 10 single air discharges were applied to the selected test point for each such area.

8.1.3 Test Result

Direct Application of ESD

Direct Contact Discharge

Applied Voltage (kV)	No. of Discharge for each point	Result	Discharged Points
4	20	N/A	Accessible metal parts of the EUT Conductive substrate with coating which is not declared to be insulating

Direct Air Discharge

Applied Voltage (kV)	No. of Discharge for each point	Result	Discharged Points
2, 4, 8	20	Pass	All accessible points where contact discharge cannot be applied such as Displays, Indicators light, Keyboard, Button, Switch, Knob, Air gap, Slots, Hole and so on

TEST REPORT**Indirect Application of ESD**

Horizontal Coupling Plane under the EUT

Applied Voltage (kV)	No. of Discharge for each point	Result	Discharged Point
4	20	N/A	At the front edge of each HCP opposite the centre point of each unit of the EUT

Vertical Coupling Plane beside the EUT

Applied Voltage (kV)	No. of Discharge for each point	Result	Discharged Point
4	20	Pass	The centre of the vertical edge of the coupling plane

TEST REPORT

8.2 Radiated Electromagnetic Field Immunity

Basic Standard :	EN 61000-4-3: 2006 + A1: 2008 + A2: 2010
Port :	Enclosure
Required Performance Criterion :	Criteria A
Level :	3.0 V/m (rms)
Test Modulation :	1kHz, 80% AM
Frequency :	80 MHz to 6000 MHz
Dwell Time :	3s
Frequency Step :	1%
Temperature :	22.0°C
Relative Humidity :	50 %
Test Facility :	Full Anechoic Chamber
Antenna Polarization :	Horizontal and Vertical
Type of Antenna :	Log-periodic / Horn
Test Distance :	3m
Test Mode :	wireless connection & EUT Standby
Test Setup :	Floor-stand

TEST REPORT

8.2.1 Block Diagram of Test Setup

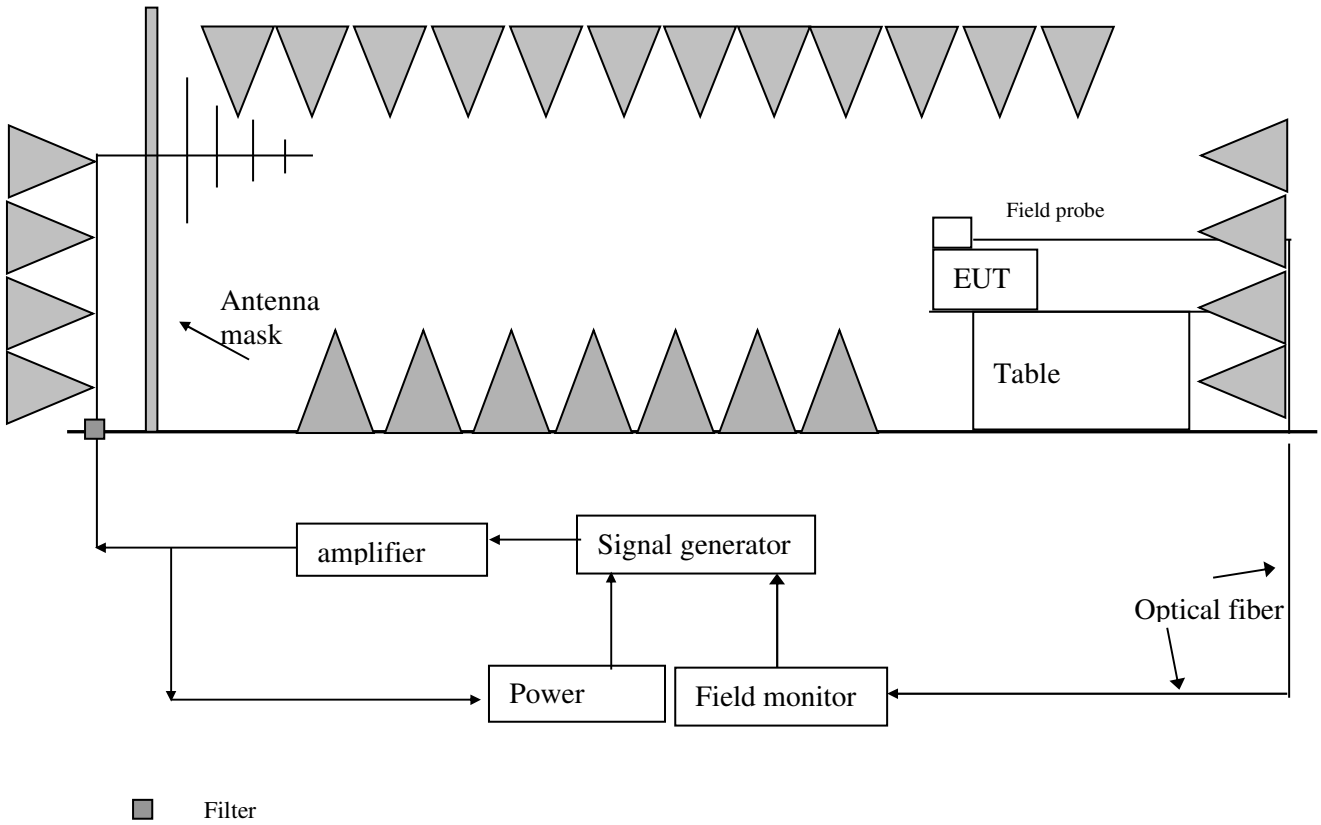

TEST REPORT

8.2.2 Test Setup and Procedure

The test was conducted in a fully anechoic chamber to maintain a uniform field of sufficient dimensions with respect to the EUT, and also in order to comply with various national and international laws prohibiting interference to radio communications.

The equipment is placed in the test facility on a non-conducting table 0.8m high (for floor standing EUT, is placed on a non-conducting support 0.1m height).

The EUT was placed on the uniform calibrated plane which is 3V/m EM field.

For all ports connected to EUT, manufacturer specified cable type and length was used, for those cables no specification, unshielded cable applied.

Wire is left exposed to the electromagnetic field for a distance of 1m from the EUT.

The EUT was arranged and connected according to its functional requirements

Before testing, the intensity of the established field strength have been checked by placing the field sensor at a calibration grid point, and with the field generating antenna and cables in the same positions as used for the calibration, the forward power needed to give the calibrated field strength was measured.

Spot checks was made at a number of calibration grid points over the frequency range 80MHz to 1000MHz, both polarizations was checked.

After calibration, the EUT is initially placed with one face coincident with the calibration plane.

The frequency range is swept from 80MHz to 6000MHz, with the signal 80% amplitude modulated with a 1 kHz sine-wave, pausing to adjust the r.f. signal level.

The dwell time at each frequency was 3s so as that the EUT to be exercised and be able to respond.

The step size was 1% of the fundamental with linear interpolation between calibrated points. Test was performed with the generating antenna facing each of the four sides of the EUT.

8.2.3 Test Result

Frequency (MHz)	Exposed Side	Field Strength (V/m)	Result
80 to 6000	Front	3V/m (r.m.s.)	Pass
80 to 6000	Left	3V/m (r.m.s.)	Pass
80 to 6000	Rear	3V/m (r.m.s.)	Pass
80 to 6000	Right	3V/m (r.m.s.)	Pass

Note: The exclusion band is: 2280 -2603.5MHz

TEST REPORT

8.3 Electrical Fast Transient/Burst

Basic Standard :	EN 61000-4-4: 2012
Port :	A.C. Power Lines
Required Performance Criterion:	Criteria B
Level:	$\pm 0.5, \pm 1.0\text{kV}$
Repetition Frequency:	5 kHz
Burst Duration:	300 ms
Test Duration	1 minute per each polarity
Test Mode:	wireless connection & EUT Standby
Test Setup:	Floor-stand
Generator Drive:	Internal
Sequence of Application:	Each One

8.3.1 Block Diagram of Test Setup

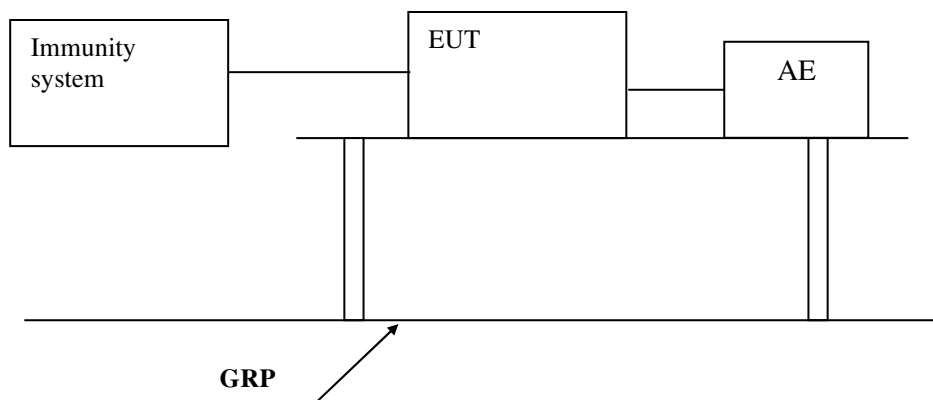

8.3.2 Test Setup and Procedure

The EUT was placed on a 0.1m high wooden table, standing on the ground reference plane 3m by 2m in size, made by steel 1mm thick.

The distance between the EUT and any other of the metallic surface except the GRP was greater than 0.5m.

The mains lead excess than 0.5m was folded to avoid a flat coil and situated at a distance of 0.1m above the ground reference plane to insure the distance between the coupling device and the EUT was 0.5m.

TEST REPORT

The EUT was arranged and connected to satisfy its functional requirement and supplied by the coupling-decoupling network.

8.3.3 Test Result

Port	Level	Result
A.C. Power ports	$\pm 1\text{kV}$	Pass
Signal ports(>3m)	$\pm 0.5\text{kV}$	N/A
wired network ports(>3m)	$\pm 0.5\text{kV}$	N/A
control ports(>3m)	$\pm 0.5\text{kV}$	N/A
DC power ports(>3m)	$\pm 0.5\text{kV}$	N/A

8.4 Surge Immunity

Basic Standard :	EN 61000-4-5: 2014+A1:2017
Port :	A.C. Power Lines
Required Performance Criterion :	Criteria B
Level :	$\pm 1\text{kV}$ Live to Neutral, $\pm 2\text{ kV}$ Live, Neutral to Earth
Generator Impedance :	2 ohm for Live to Neutral, 12 ohm for Live, Neutral to Earth
Repetition Rate :	1 minute
Test Mode :	wireless connection & EUT Standby
Test Setup :	Floor-stand
Surge Generator Trigger :	Internal
Phase Angle :	0°, 90°, 180°, 270°

8.4.1 Block Diagram of Test Setup

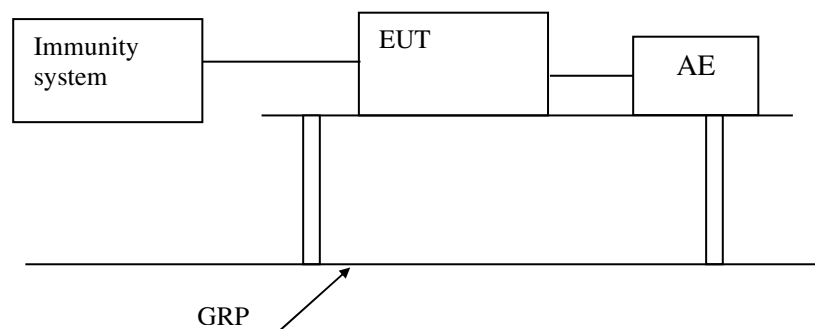

TEST REPORT

8.4.2 Test Setup and Procedure

The surge was applied to the EUT power supply terminals via the capacitive coupling network.

Decoupling networks were required in order to avoid possible adverse effects on equipment not under test that might be powered by the same lines and to provide sufficient decoupling impedance to the surge wave so that the specified wave might be developed on the lines under test.

The EUT was arranged and connected according to its functional requirements.

The EUT was placed on a 0.1m high wooden support above the GRP), supplied by the coupling-decoupling network, and arranged and connected to satisfy its functional requirement. The power cord between the EUT and the coupling/decoupling network was less than 2 meters.

8.4.3 Test Result

Level	Result
Between Phase And Phase: 1kV	N/A
Between Phase And Neutral: 1kV	Pass
Between Phase And Earth: 2kV	N/A
Between Neutral And Earth: 2kV	N/A

8.5 Injected Current

Basic Standard :	EN 61000-4-6: 2014
Port :	A.C. Power Lines
Required Performance Criterion :	Criteria A
Level :	3.0V (rms)
Test Modulation :	1 kHz, 80% AM
Frequency :	0.15 MHz to 80 MHz
Dwell Time :	3s
Frequency Step :	1%
Temperature :	23.2°C
Relative Humidity :	58.4 %

TEST REPORT

Test Mode :	wireless connection & EUT Standby
Test Setup :	Floor-stand
Equipment Under Test (EUT):	Single Unit

8.5.1 Block Diagram of Test Setup

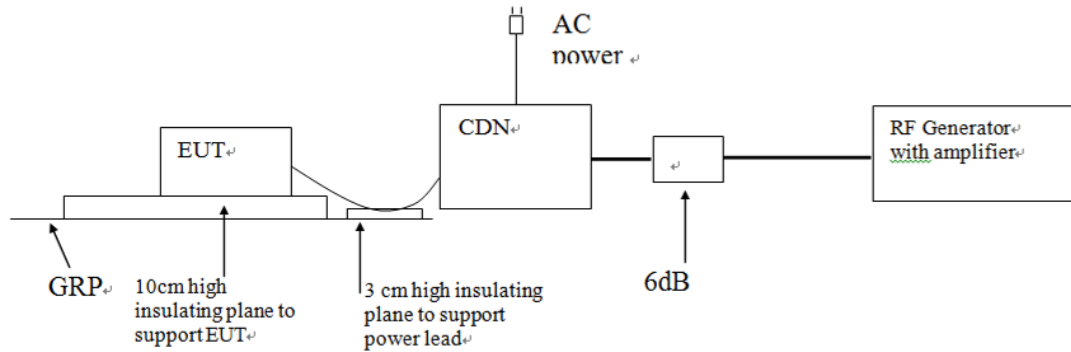

8.5.2 Test Setup and Procedure

The EUT was placed on an insulating support of 0.1m height above a ground reference Plane, arranged and connected to satisfy its functional requirement. All relevant cables were provided with the appropriate coupling and decoupling devices at a distance between 0.1m and 0.3m from the projected geometry of the EUT on an insulating support of 0.03m height above the ground reference plane. Test voltage was verified before each testing though power meter combined in the RF generator with AMP. Dwell time was set to 3s and step was set as 1% to keep sufficient response time for EUT. The frequency from 0.15MHz to 230MHz was checked.

8.5.3 Test Result

Port:	Frequency (MHz)	Level	Result
A.C. Power Lines	0.15 to 80	3V (r.m.s.)	Pass
signal ports(>3m)	0.15 to 80	3V (r.m.s.)	N/A
wired network ports(>3m)	0.15 to 80	3V (r.m.s.)	N/A
control ports(>3m)	0.15 to 80	3V (r.m.s.)	N/A
DC power ports(>3m)	0.15 to 80	3V (r.m.s.)	N/A

TEST REPORT

8.6 Voltage Dips and Interruptions

Basic Standard :	EN 61000-4-11: 2004
Port :	A.C. Power Lines
Required Performance Criterion:	Criteria B: 0 % U_T for 0.5 cycle, 0% U_T for 1 cycle, 70 % U_T for 25 cycles, Criteria C: 0 % U T for 250 cycles (TT & TR)
Level:	0 % U_T for 0.5 cycle
	0% U_T for 1 cycle
	0 % U_T for 250 cycle
	70 % U_T for 25 cycle
No. of Dips/Interruptions	3
Test Mode:	wireless connection & EUT Standby
Test Setup:	Floor-stand

8.6.1 Block Diagram of Test Setup

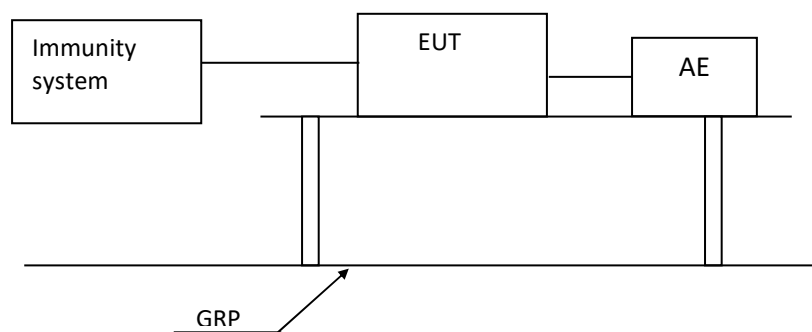

8.6.2 Test Setup and Procedure

The EUT was placed on an insulating support of 0.8m height, standing on a ground reference plane, and arranged and connected to satisfy its functional requirement

The test was performed with the EUT connected to the test generator with the shortest power supply cable as specified by the EUT manufacturer.

TEST REPORT

The EUT was tested for each selected combination of test level and duration with a sequence of three dips/interruptions with intervals of 10 s minimum. Each representative mode of operation was tested.

Abrupt changes in supply voltage was occur at zero crossings of the voltage.

8.6.3 Test Result

Test Condition		Result
Test Level in %UT	Duration(s)	50 Hz
0	0.01	Pass
0	0.02	Pass
0	5	Pass
70	0.5	Pass

Remark: UT is the rated voltage for the equipment.

TEST REPORT

9. APPENDIX I - PHOTOS OF TEST SETUP

Conducted Emission



ESD Immunity



TEST REPORT

Inject current immunity



Radiated EM field immunity

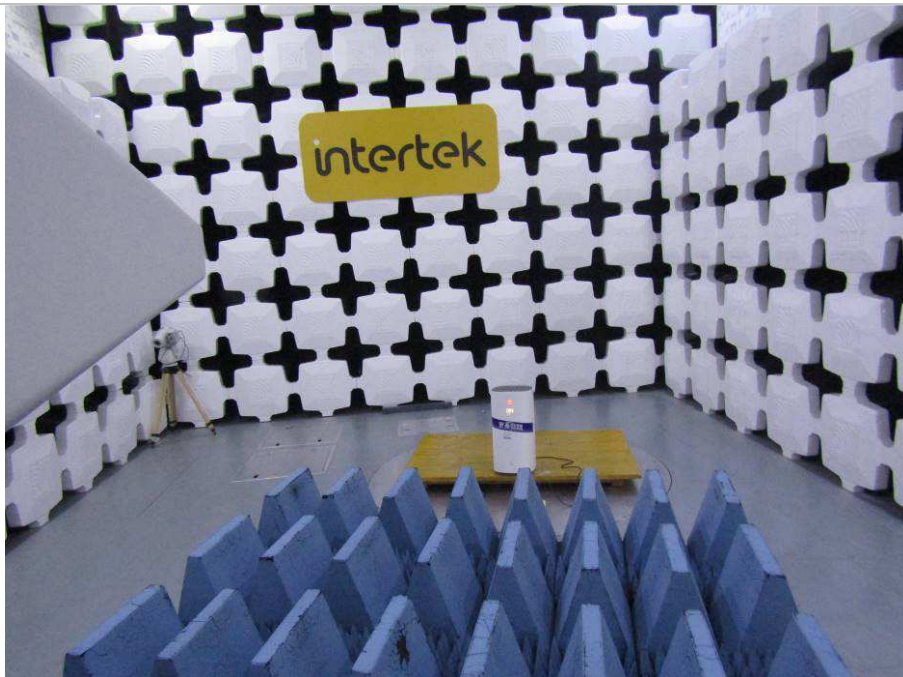

TEST REPORT

EFT Immunity



Surge and DIP Immunity



10. APPENDIX II – PHOTOS OF EUT

Please refer to 201225119GZU-005 test report for more details.

*****End of Report*****